

The logo for Atlas Steels AIFacade features a stylized 'A' icon composed of two blue lines and a dot, followed by the text 'Atlas Steels' in a bold blue font and 'AIFacade' in a larger, bold blue font with a registered trademark symbol.

Atlas Steels AIFacade®

Installation and Technical Manual
Version 3.1 | 21/03/2025



Table of Contents

01	Introduction to AlFacade®	2
02	Product Specifications	3
	2.1 Overview	
	2.2 Material Composition	
	2.3 Standard Panel Size	
03	Finish & Coating Specification	4
04	Material Data	5
05	Installation Details	6
	5.1 Installation Considerations	
	5.2 Protective Film	
	5.3 Installation Guidelines	
	5.4 Drawings	
06	Fabrication Details	21
	6.1 Fabrication Considerations	
07	Warranty	24
	7.1 Warranty Outlined	
08	Storage & Handling	25
	8.1 Handling	
	8.2 Transport	
	8.3 Storage	
09	Service Centre Locations	26

Introduction to Atlas Steels AlFacade®

As the team behind the largest supplier of Aluminium, Stainless Steel & Specialty Metal products in Australia, the people of Atlas Steels are driven by wanting to be our customers first choice in specialty metals.

Atlas Steels has a long and proud history of customer service in Australia which commenced in 1939 with the entry into Australia of Atlas Steels Canada, a leading Canadian steel supplier founded in 1918. From these roots Atlas Steels built a distribution network with 8 customer service sites across Australia.

The Atlas Steels reputation is built on over 80 years of service of our customers. The belief that our customers are our priority is core to the values of the Atlas Steels people, whose talents and energy are aimed at building long term relationships with our customers by adding value to their businesses.

Atlas Steels AlFacade® is a 3.0mm or 4.0mm solid aluminium cladding that forms part of the range of non-combustible products available through Atlas Steels. The AlFacade® aluminium cladding meets the requirements of the National Construction Code (NCC) and is compliant on all Type A, B & C class of construction.

Atlas Steels AlFacade® solid aluminium panel has high impact resistance, the panels can be fabricated and processed via CNC machining Including, pan break & break press folding, rolled and curved, the pre-finished cladding panels have a PVDF coating system with a proven history for its superior quality colour range and design integrity.

02

Atlas Steels AlFacade® Product Specification

- AlFacade® is a solid aluminium PVDF coated cladding, tested to AS1530.1 and deemed non combustible. The AlFacade® aluminium cladding is suitable for a broad range of commercial and residential construction projects and complies with the current BCA Amendment-1 2019 and meets the requirements within the National Construction Code (NCC)
- Polyvinylidene flouride (PVDF) Coating system.
- 20 years warranty, subject to standard terms and conditions.
- Atlas Steels AlFacade® has been tested to AS4284 and meets the weatherproofing requirements for FP1.4
- Atlas Steels AlFacade® is certified to ISO 9001:2015 & ISO 14001:2015 for designed, manufactured and coating system.

Material Composition

Atlas Steels AlFacade® is a 3.0mm or 4.0mm 3003 Series H22 100% solid aluminium panel, suitable for all Type A, B, & C class of construction.

- A. Protective film
- B. PVDF coating
- C. Pre treatment layer
- D. 3mm or 4mm aluminium
- E. Protective wash coat to back of panel

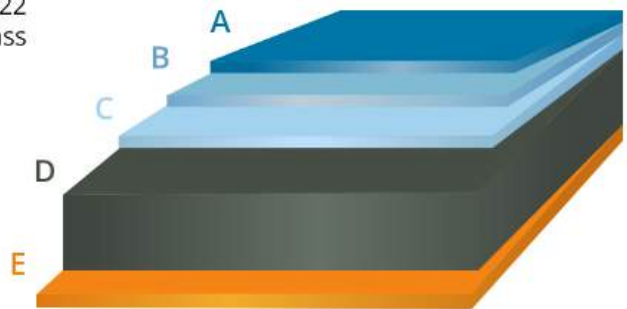

Standard Panel Dimensions

WIDTH	LENGTH	THICKNESS
1250 / 1575	2500 3200 4000	3mm / 4mm

**Note - Custom width (1800mm max) & lengths are available with minimum MOQ per width and size.

03

Coating System

Atlas Steels AlFacade® panels are coated with a Beckers Group coating system. Beckers are a leading worldwide supplier of industrial coatings and the global market leader of coil coatings. Beckers are focused on developing sustainable coatings – their vision is to become the most sustainable industrial coatings company in the world. Beckers expertise is based on a long history dating back over 150 years, their history includes the manufacturing of high performance coating solutions for a wide variety of applications, including an extensive range of colours.

Atlas Steels AlFacade® 2 or 3 coat (PVDF) Polyvinylidene fluoride coating is a pure thermoplastic fluoropolymer that is non-reactive and possesses multiple benefits including complying with AAMA2605:2017A.

PVDF coatings are especially resistant to solvents, acids & have a very low density compared to other fluoropolymers .

Beckers most UV resistant topcoat system based on a blend of polyvinylidene fluoride and acrylic resins in 70/30 – 80/20 ratios. Available in mid to low gloss levels. Only the most durable pigments are used to achieve the Beckry®Fluor colour range



- Coating complies with AAMA2605:2017A
- Chemical resistance (ASTM D543): excellent
- Abrasion resistance (ASTM D4060): excellent
- PVDF coating thickness: 30 micron
- Gloss 20 – 80% matt/flat gloss
- Reverse = 7 micron grey wash coat

Atlas Steels AlFacade® is able to be colour matched to any colour that the Architect, client, builder requires from any existing colour range (subject to minimum order quantities).

04

Material Data

Test Results

Test Standard	RESULT
AS1530.1	Non - Combustible
AS1530.3	PASS
	Ignitability Index 0
	Heat Evolved 0
	Spread of Flame 0
	Smoke Developed 1

Thermal Performance

Thermal resistance from -50°C To + 80°C

Test Standard	Thermal Resistance 1A M2.K/W	Thermal Resistance 1A M2.K/W
---------------	---------------------------------	---------------------------------

Material Data Sheet

Physical property	VALUE
Tensile strength - ultimate, Ft _u * (MPa)	120-160
Tensile strength - yield, Ft _y * (MPa)	80 min
Elongation	8% min
Compressive strength, F _{cy} (MPa)	131
Shear strength - ultimate, F _{su} (MPa)	83
Shear strength - yield, F _{sy} (MPa)	69
Bearing strength - ultimate, F _{bu} (MPa)	276
Bearing strength - yield, F _{by} (MPa)	172
Compressive MOE, E (MPa)	70000
Thermal expansion coefficient	23
Fatigue strength (MPa)	60
Modulus of resilience (Kj/M ³)	130
Embodied carbon (kg-CO ₂ /kg)	8.1

05

Installation Details

The following list of installation considerations and details need to be taken into account prior to the start of panel installation:

- Atlas Steels AlFacade® has a directional arrow on the protective film, ensure arrow direction is consistent with the installed cladding layout to prevent any variation in the finish due to light refraction/reflection.
- Different production lots may show as a minor colour variation, an overall project order is recommended to ensure colour consistency across the project.
- When aluminium Z angles are installed onto galvanised top hats, an isolation tape/barrier should be used to separate dissimilar metals.
- Atlas Steels AlFacade® is to be installed in a cassette fix method on Type A & B constructions, refer to the following installation drawing.
- Atlas Steels AlFacade® is to be installed on a BCA compliant wall or wall system that meets the current NCC requirement, including variations of wall types for example, load bearing, non-load bearing, wall types that require a Fire Resistance Level (FRL).

Protective Film

- Ensure the protective film is completely removed from within express joints before they are caulked with silicon.
- To avoid glue residue on panel surface from exposure to weathering and UV light, the protective film will need to be removed from the panels within 45 days of installation. A clear protective film is also available (MOQ may apply) which needs to be removed within 25 days of installation.
- Under no circumstance should you apply PVC tapes, polyurethane or silicone sealant. These products can penetrate the film, or the panel surface, resulting in a change in the PVDF coating gloss level.
- Do not apply any spray paint or write with permanent marker on the protective film, as the colour may penetrate the film and affect the painted panel surface.
- After removal of the protective film ensure no scratches/damage will occur to the panel surface if still working within the area.

Installation Guidelines

General guideline, sequence of installation is as follows:

- Installation of an approved/compliant vapor permeable membrane as per manufacturers requirements.
- Install top hats vertically or horizontally ensuring they are levelled and fixed at appropriate centres to meet area/building wind load requirement's, with 10-12 gauge hex head class 3 screws.
- CNC fabricate and prepare Atlas Steels AlFacade® for installation.
- Install Atlas Steels AlFacade® panels to the top hats, then fix through the aluminium Z angles into top hats at the recommended centers for wind loading requirements.
- Caulking + backing rod applied to panel joints as per manufacturers recommendations, do not caulk panel joints if temperature is above 30 degrees celcius.
- Remove all the protective film from Atlas Steels AlFacade® within 45 days of installation.

Material AS/NZS Properties 1664 3003 H22

E	70000 MPa	<-- Compressive modulus of elasticity	<-- AS/NZS 1664.1 Table 3.4 (A) for Alloy 3003 Group
G	26250 MPa	<-- Shear modulus of elasticity	<-- AS/NZS 1664.1 Clause 3.4.8.3
t	3.00 mm	<-- Plate thickness	
F _{tu}	120 MPa	<-- Tensile ultimate strength	<-- Mill Certificate (range 120MPa - 160MPa)
F _{ty}	80 MPa	<-- Tensile yield strength	<-- Mill Certificate (minimum)
F _{cy}	124 MPa	<-- Compressive yield strength	<-- Extrapolated from Table 3.3 (A) AS/NZS 1664.1 3003-H16
f _y	0.95	<-- Yield capacity factor	<-- AS/NZS 1664.1 Clause 3.4.2 & 3.4.3
f _u	0.85	<-- Ultimate capacity factor	<-- AS/NZS 1664.1 Clause 3.4.2 & 3.4.3
k _t	1.0	<-- Coefficient for tension members	<-- AS/NZS 1664.1 Table 3.4 (B)
f _{F L}	135 MPa	<-- Limit state bending stress.	<-- AS/NZS 1664.1 Clause 3.4.2 & 3.4.3

Material AS/NZS Properties 1664 3003 H22

E	70000 MPa	<-- Compressive modulus of elasticity	<-- AS/NZS 1664.1 Table 3.4 (A) for Alloy 3003 Group
G	26250 MPa	<-- Shear modulus of elasticity	<-- AS/NZS 1664.1 Clause 3.4.8.3
t	4.00 mm	<-- Plate thickness	
F _{tu}	120 MPa	<-- Tensile ultimate strength	<-- Mill Certificate (range 120MPa - 160MPa)
F _{ty}	80 MPa	<-- Tensile yield strength	<-- Mill Certificate (minimum)
F _{cy}	124 MPa	<-- Compressive yield strength	<-- Extrapolated from Table 3.3 (A) AS/NZS 1664.1 3003-H16
f _y	0.95	<-- Yield capacity factor	<-- AS/NZS 1664.1 Clause 3.4.2 & 3.4.3
f _u	0.85	<-- Ultimate capacity factor	<-- AS/NZS 1664.1 Clause 3.4.2 & 3.4.3
k _t	1.0	<-- Coefficient for tension members	<-- AS/NZS 1664.1 Table 3.4 (B)
f _{F L}	135 MPa	<-- Limit state bending stress.	<-- AS/NZS 1664.1 Clause 3.4.2 & 3.4.3

Notes

General

These drawings shall be read in conjunction with all relevant Architectural and other consultants drawings and with any other written instructions issued during the course of the contract. Engineering drawings shall not be scaled. Materials and workmanship shall be in accordance with the Building Code of Australia and relevant S.A.A codes and documents listed in Part 14 of the BCA, substitutions shall not be permitted without the approval of the Engineer. The Builder is to ensure that during construction the structure shall be maintained in a stable condition and that no part shall be overstressed.

Footings

All workmanship shall be in accordance with AS2870. All footings shall be based on solid ground, with a safe bearing capacity as noted below. The final level and verification of bearing pressure shall be determined by the Engineer on site during excavations. All foundations must be inspected and approved by the relevant Building inspector before concrete is poured.

Concrete

All workmanship and materials shall be in accordance with AS3600. Concrete compression strength at 28 days to be as noted on drawings. Testing as defined for project control. Max slump 100mm. Normal aggregate size 20mm.

Clear concrete cover to reinforcement unless otherwise noted to be:

	Cast against form work & exposed to the ground or water	Cast against form work & sheltered location	Cast against ground
Pad footings	65	-	75
Strip Footings	50	-	65
Beams	40	25	65
Slabs	40	20	65
Column & Walls	50	40	75

Form work must comply with AS13610. Conduits, pipes, etc. are not to be placed in concrete cover.

Reinforcement must be securely fixed in position to prevent displacement and supported on bar chairs spaced at 1 metre centres. On no account shall masonry be built on concrete slabs or beams until form work and props have been removed. Concrete sizes shown do not allow for finishes and must not be reduced or holed without the Engineers approval. Slabs and beams are to be poured together.

Concrete must be kept free of supporting brickwork by 2 layers of a suitable membrane (malthoid etc.). Vertical faces of concrete must be kept free by a 12mm thickness of bituminous impregnated caneite or similar. Construction joints where not shown will be located to the approval of the Engineer. All concrete slabs to be moist cured for a minimum of 7 days after the concrete is poured.

Reinforcement notations:

R denotes structural grade plain round bars to AS1302.

S denotes structural grade deformed bars to AS1302.

Y denotes tempered bar to AS1302 (410Y grade)

N denotes tempered bar to AS1302 (500N grade)

F denotes hard drawn wire reinforcing fabric to AS1304 (450 grade)

SL denotes hard drawn wire reinforcing fabric to AS1304 (500 grade)

The number following the bar grade symbol represents the nominal bar diameter in mm or the fabric reference number. 3 No. Y12 x 1500mm long bars shall be placed diagonally across each corner of any wall or slab openings

Form work shall be left in place, unless otherwise noted for the following times:

1.) Beam sides, vertical wall and columns	4 days
2.) Slabs up to 45m span (form work removed and slab repped)	10 days
3.) Removal of props under slabs	21 days
4.) Beam soffits up to 7.5m span (props left under)	14 days
5.) Removal of props to beams	28 days

Camber to suspended slabs and beams to be 5mm for every 2500mm of U.N.O. Water stops to be provided in all construction joints of walls and slabs exposed to weather or water. Reinforcement is represented diagrammatically and not necessarily in true projection. Splices in reinforcement shall be made only in positions shown. Welding of reinforcement will not be permitted unless shown on the structural drawings.

Brickwork and Blockwork

All workmanship and materials shall be in accordance with AS3700. Unless detailed otherwise on Architectural or Engineering drawings, provide control joints in brick and block walls of at 6.0m centres.

Steelwork

Welds unless otherwise noted to be 6.55mm continuous fillet laid down with approved electrodes. Butt welds must develop the full tensile strength of the member. Bolts unless otherwise noted to be 20mm diameter black bolts in 1.5mm clearance holes, gusset plates unless otherwise noted to be 10mm thick.

The fabricator must provide all clear holes etc. For fixing of timber members, as required by Architectural drawings and specifications. All steelwork shop drawings must be approved by WA Moore & Associates before fabrication is commenced. Approval does not cover checking dimensions or layout, or preclude the fabricator from the responsibility for the correctness of the work.

All steelwork other than that encased by concrete and mating surfaces of Friction Grip Bolt Connections shall be given a coat of approved steel priming paint. Camber to structural steel roof beams, trusses, portals, etc. to be 3mm for every metre span unless otherwise noted.

Concrete encased structural steelwork shall be enclosed with ASF 52 mesh, placed 25mm clear of steel member. Encasing to provide 25mm minimum cover (50mm where exposed to earth) Where connections are not shown provide 10mm mild steel cleats and 2 No. M20 bolts. All external steelwork to be hot dipped galvanised to AS1650 unless otherwise noted. All structural steelwork below ground to be encased by concrete 75mm min. all round. All structural steelwork to be C300 grade unless specified otherwise.

Timber

All workmanship and materials shall be in accordance with AS1684 & AS1720. Timber shall be protected from termite infestation in accordance with AS3660. All timber in contact with ground or not protected from weather exposure and associated moisture ingress shall be of durability class 1 or 2 in accordance with AS1720.1 & AS1720.2 or preservative treated in accordance with AS1604.

Where required all timber shall be preservative treated for the appropriate hazard level in accordance with AS1604. The specified hazard levels are as follows:

Interior, above ground.	H2
Exterior, above ground.	H3
Exterior in ground contact.	H4 & H5

Installation Drawings

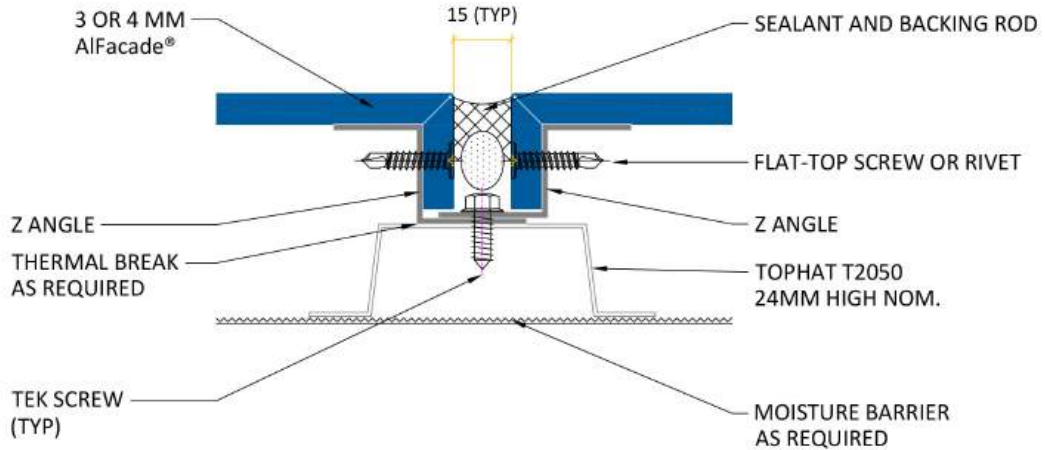

TYPICAL PANEL JOINT DETAILS DET-A

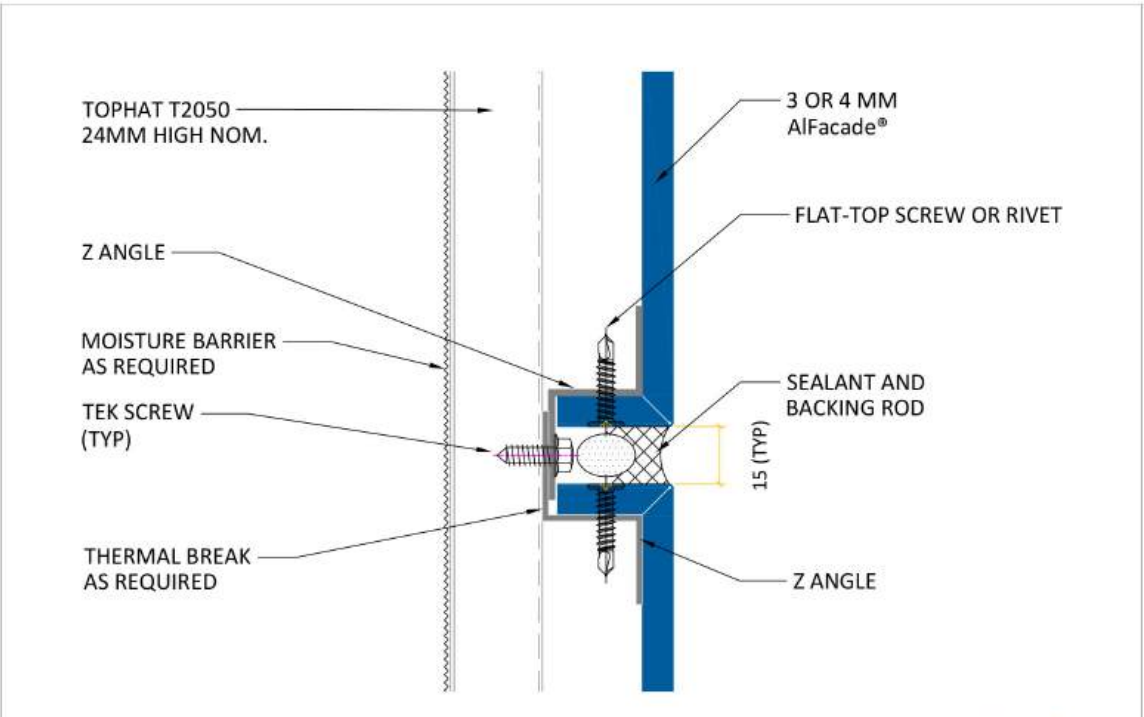

HORIZONTAL JOINT DETAIL DET-B



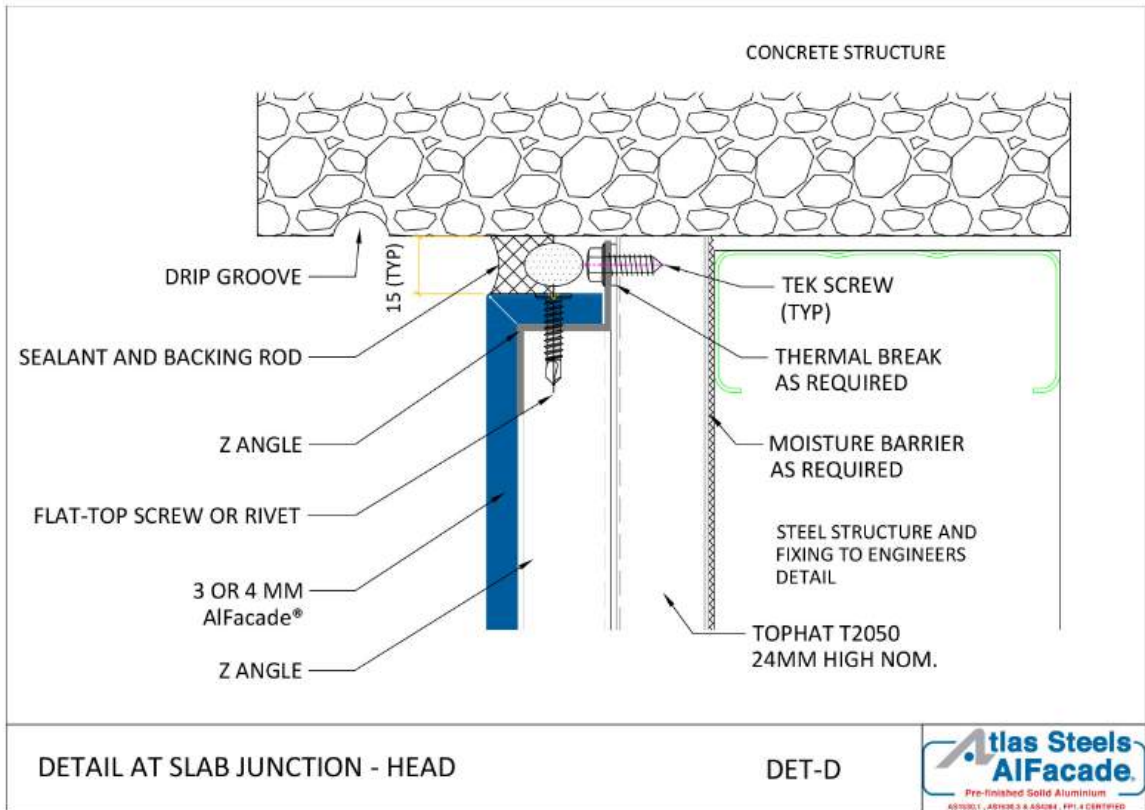
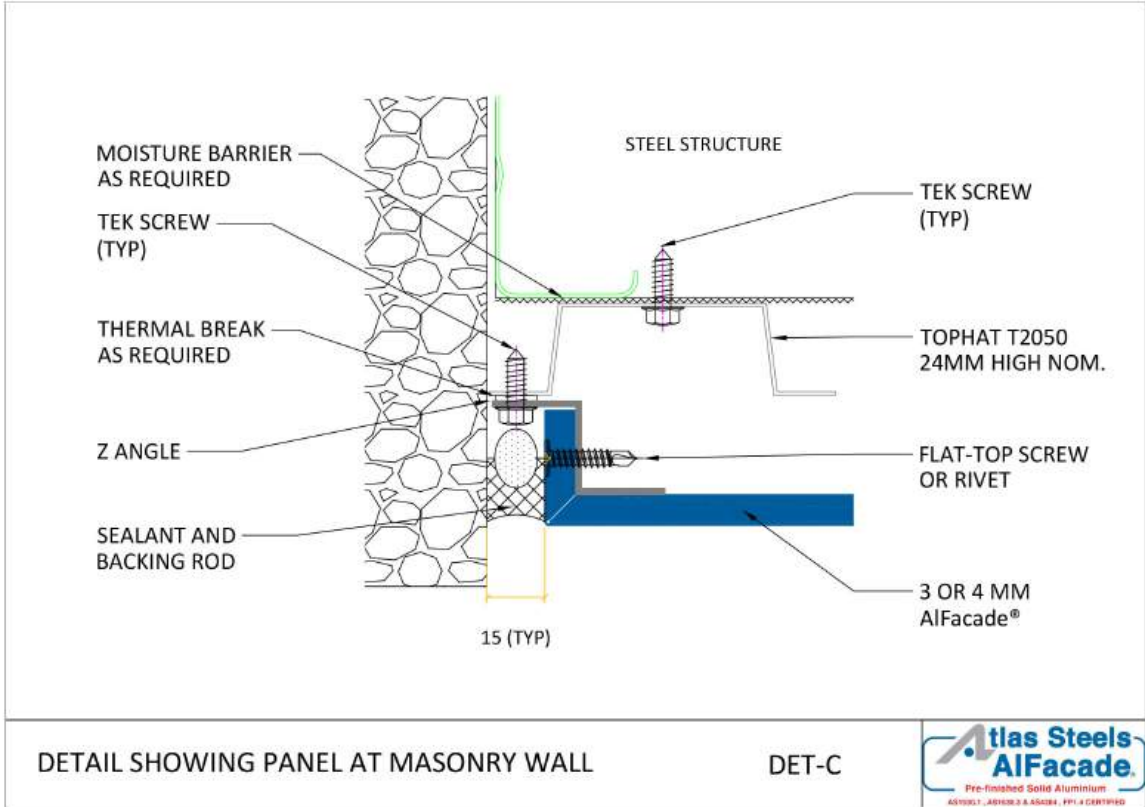

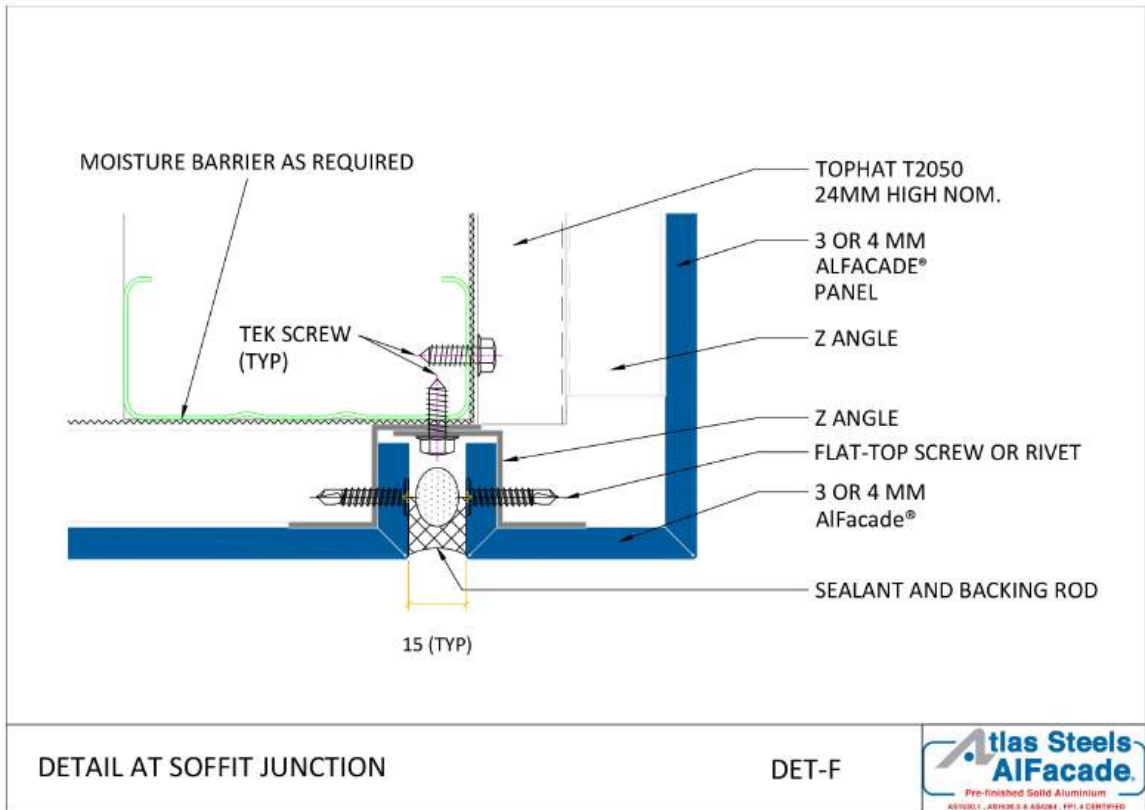
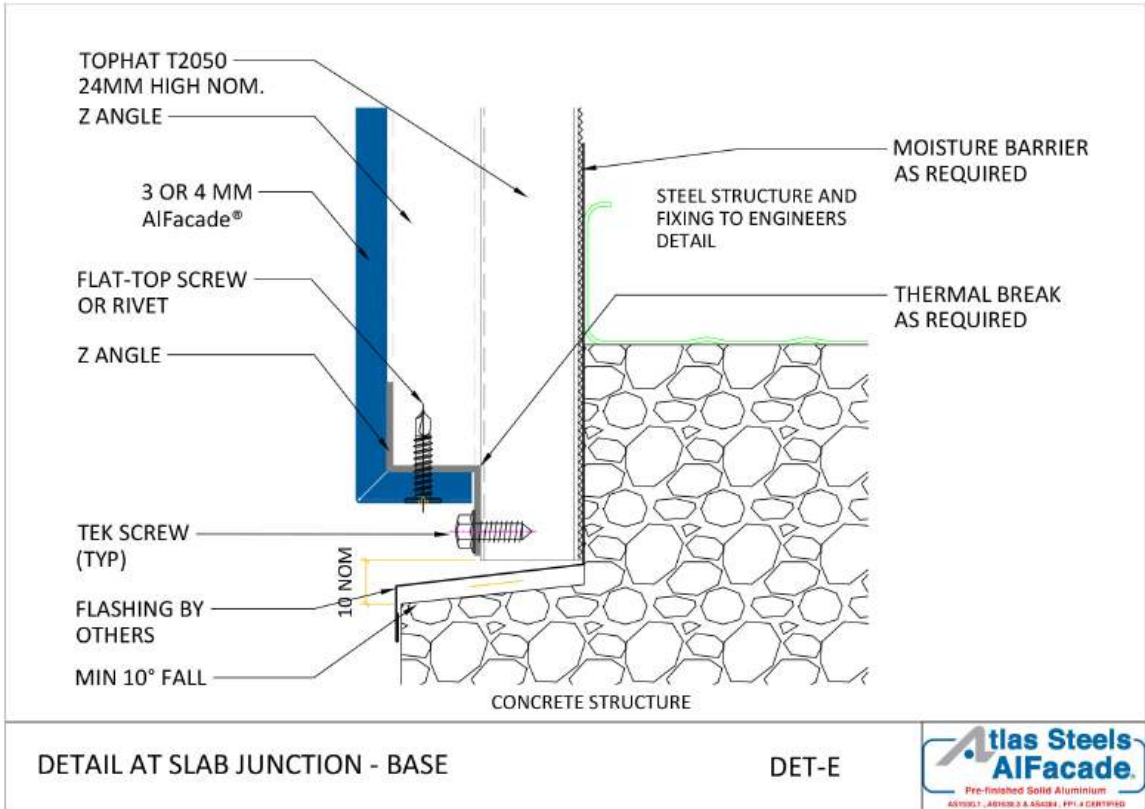

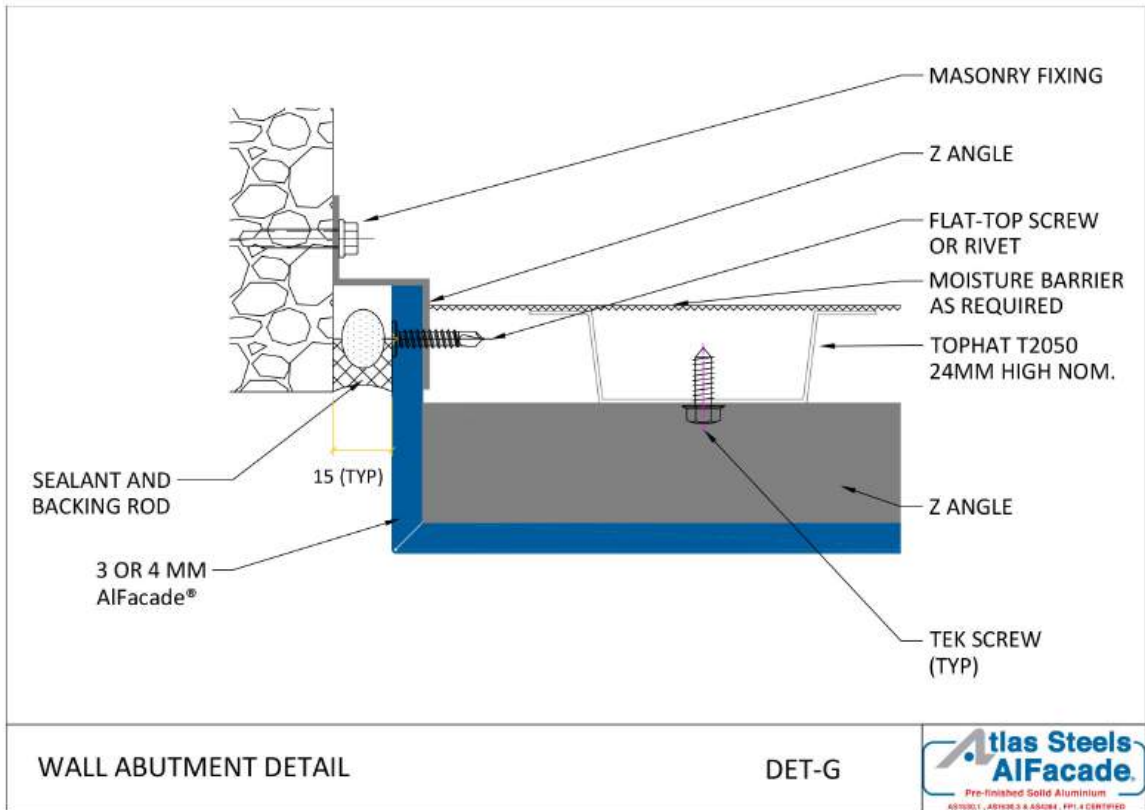
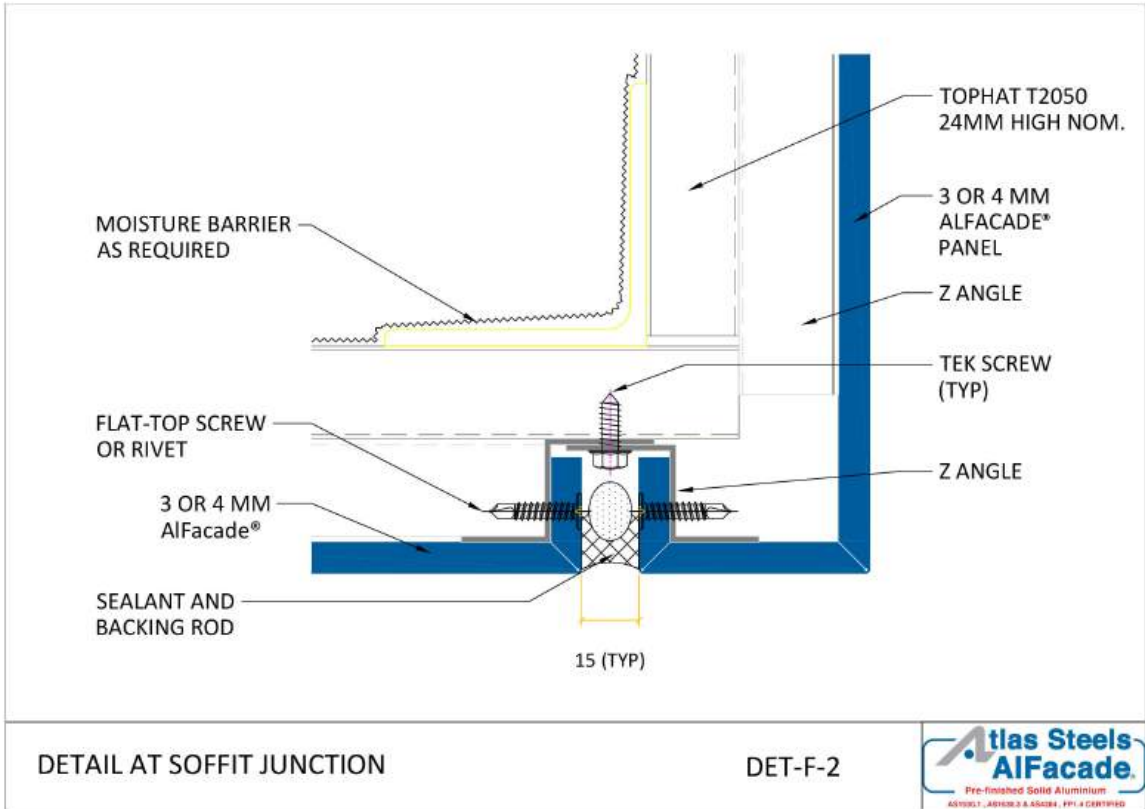

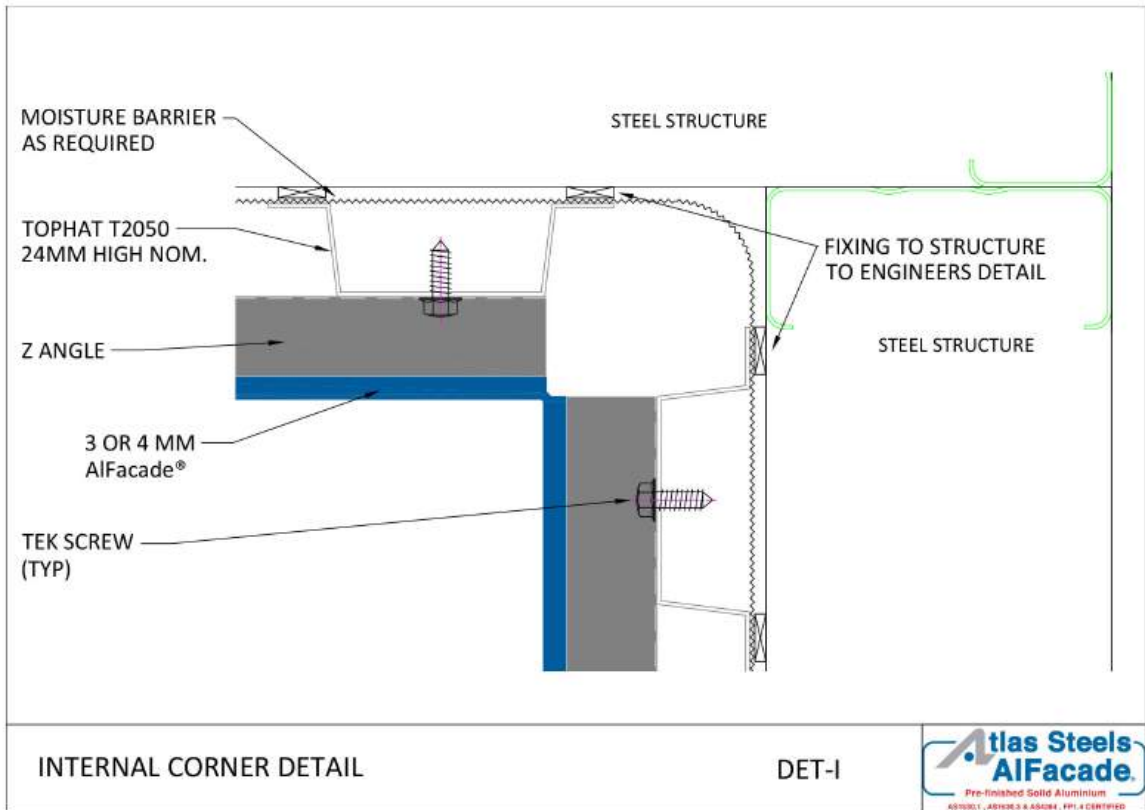
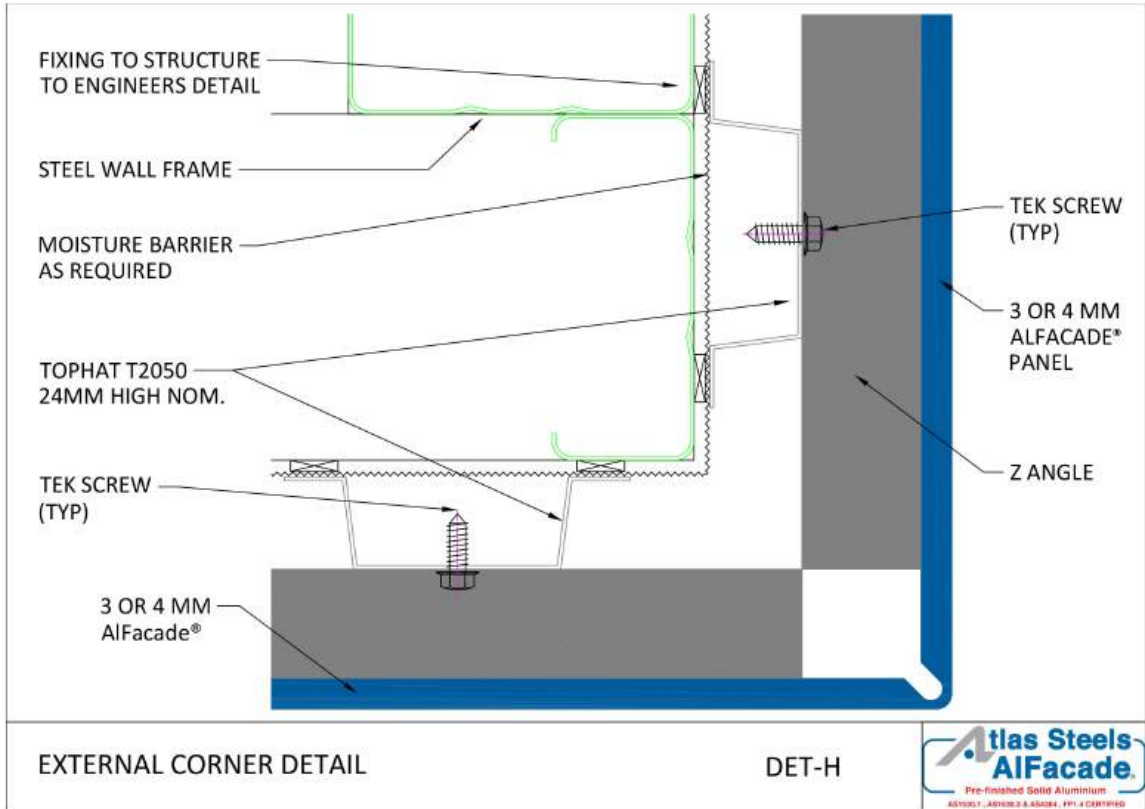

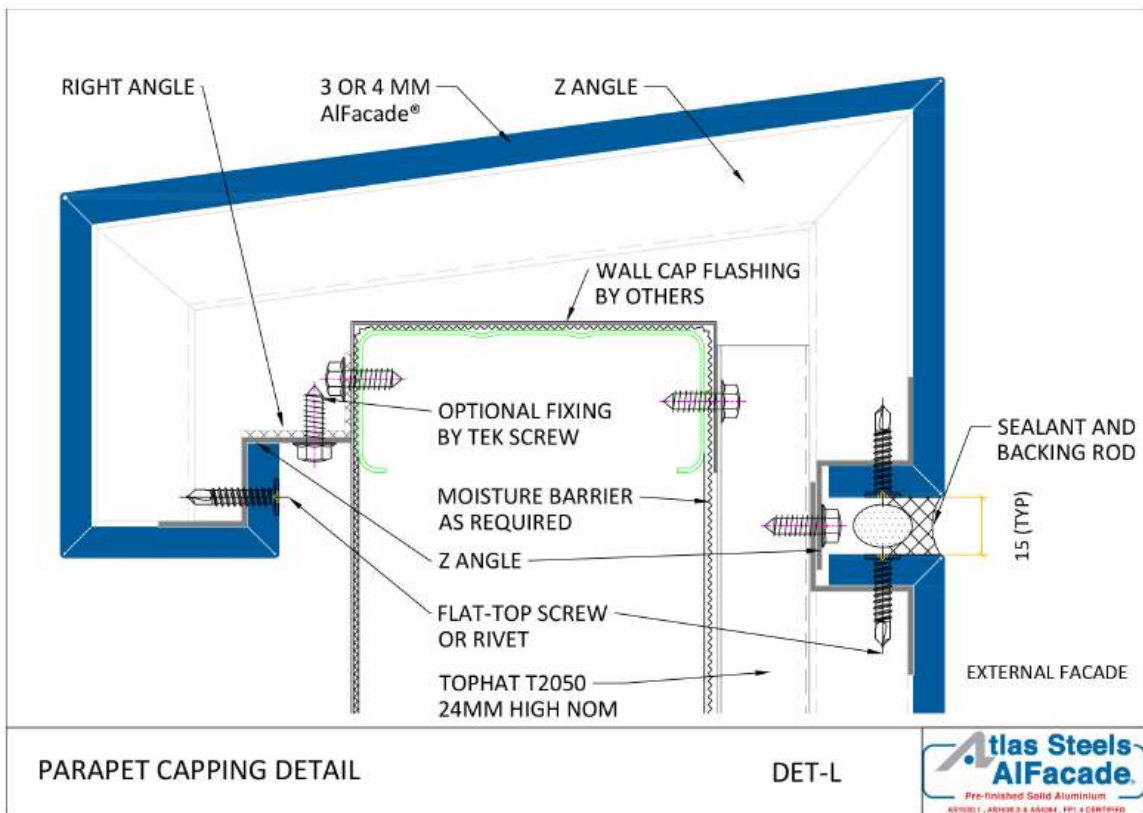
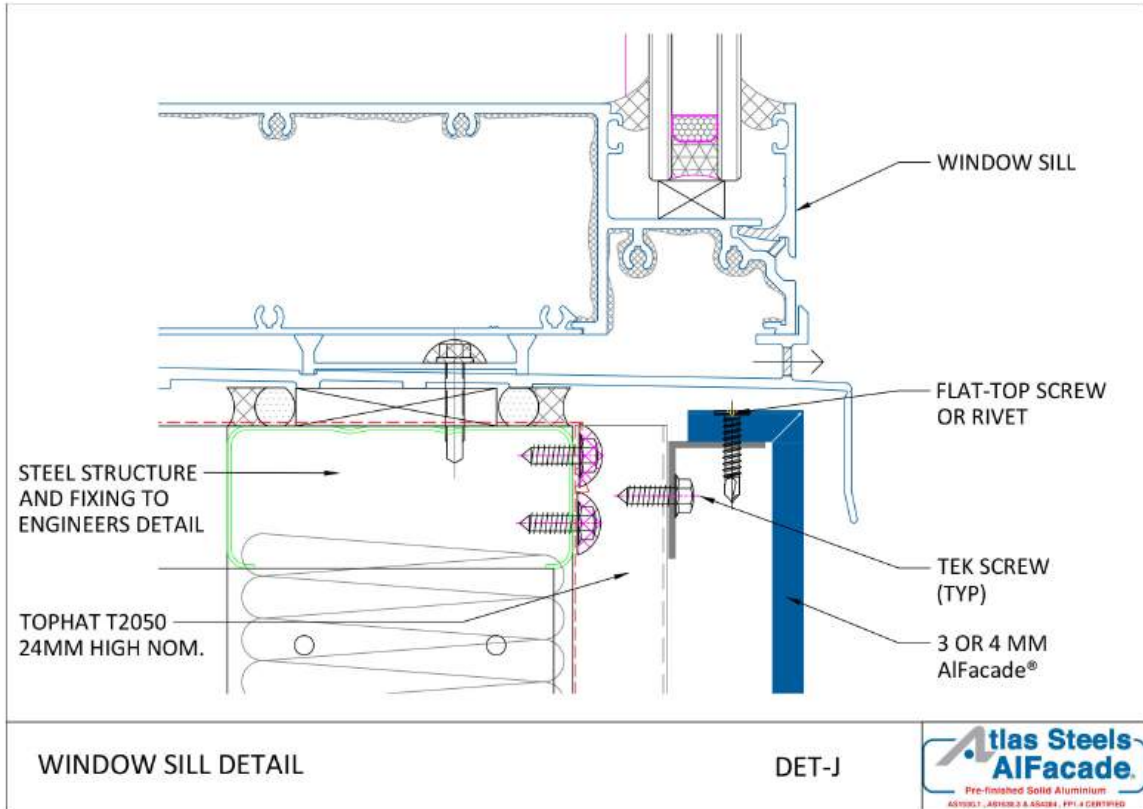

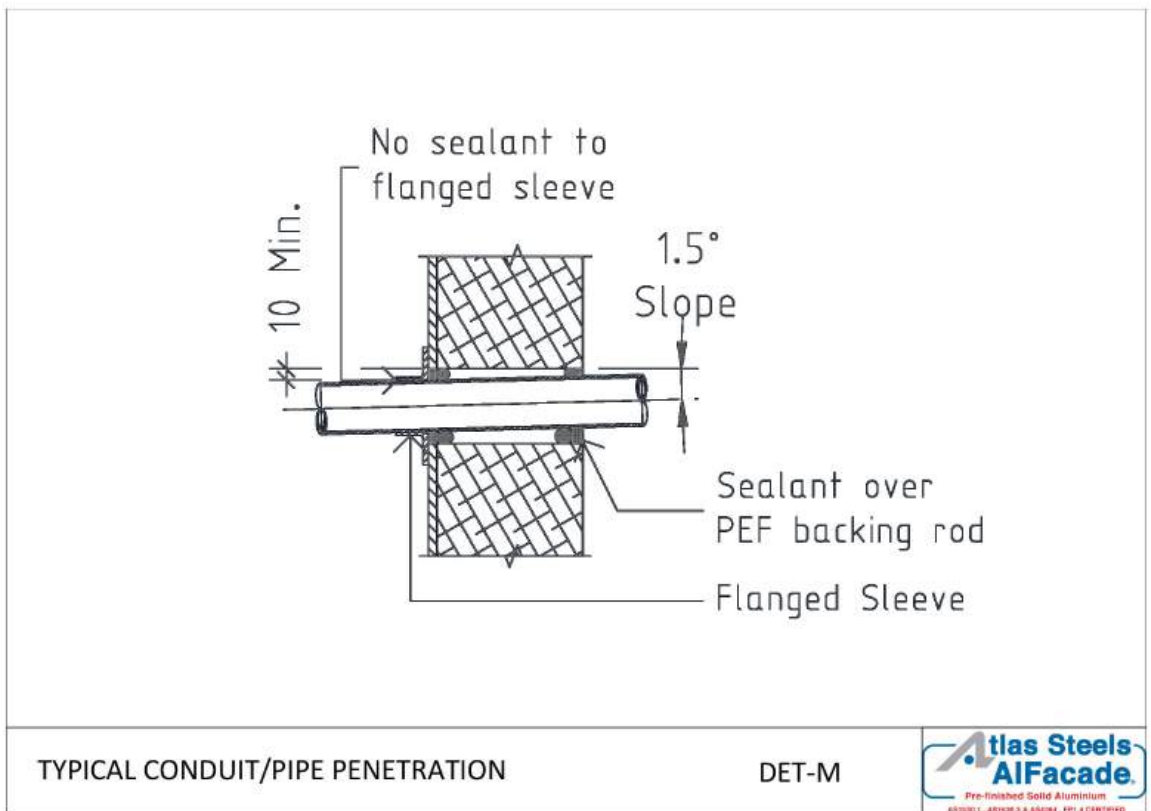
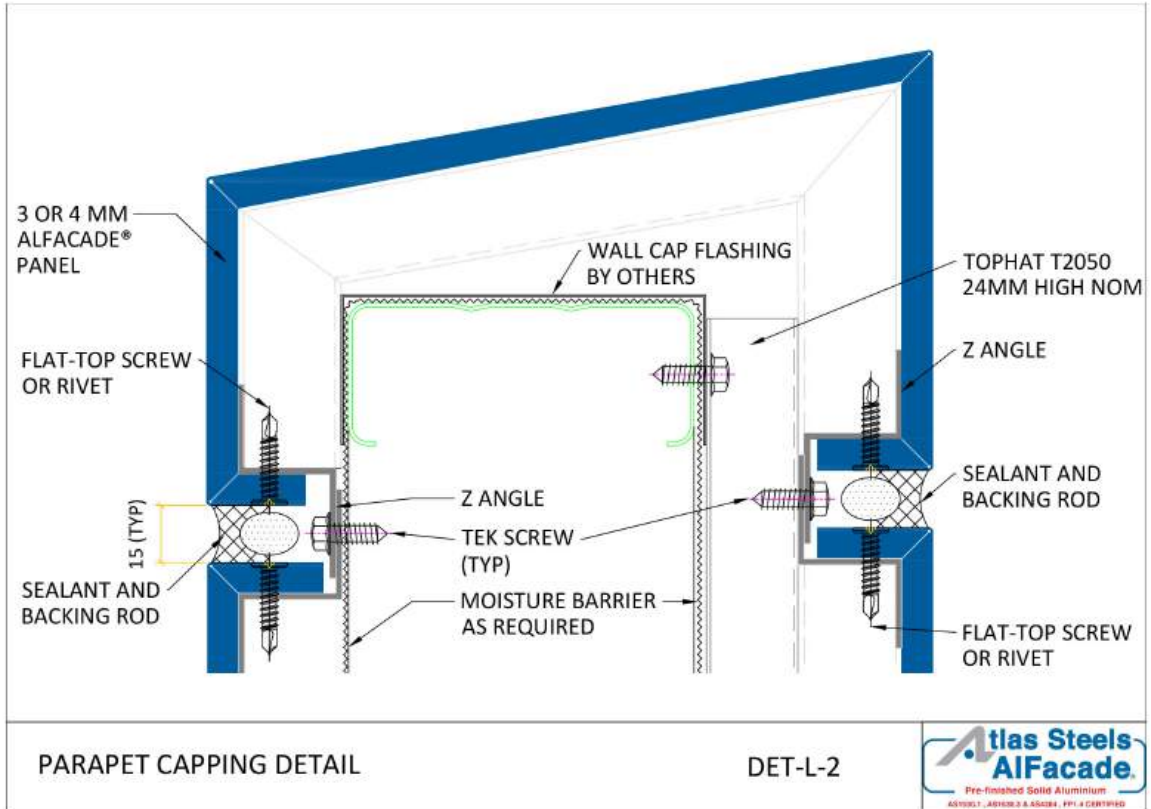

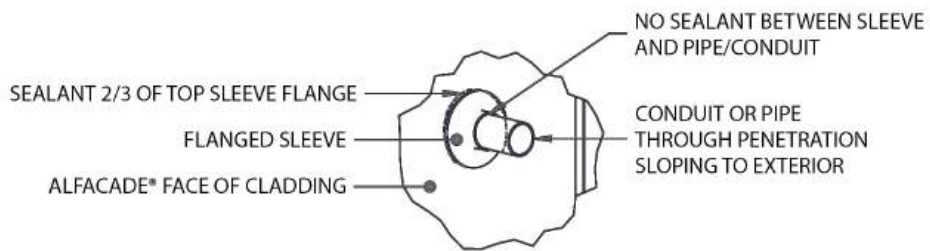

TYPICAL CONDUIT/PIPE PENETRATION

DET-N



06

Atlas Steels AlFacade® Fabrication Details



Cutting

Atlas Steels AlFacade® can be cut using various types of saw with an appropriate type aluminium blade used in your circular saw, wall saw or jigsaw, consult with your supplier for best suited option. A cutting coolant system is recommended when processing.

Tool

(CNC) 4.76mm single flute upsiral cutter

Feed

1,500mm/minute

Spindle

21,000mm/minute

NOTE: angle entry when cutting panel is recommended. Cutting fluid required.



Grooving

The preferred V Groove routing method of Atlas Steels AlFacade® is to be done via CNC machine to maintain consistency, of routed depth, by leaving 0.8 to 1.0mm of material at the base of the route. A cutter coolant system is recommended when processing.

Tool

(CNC) 4.76mm single flute upsiral cutter

Feed

1,500mm/minute

Spindle

21,000mm/minute

NOTE: angle entry when routing panel is recommended. Cutting fluid required.



Radius/Profile Cutting

The use of CNC machine, jigsaws and waterjet cutters are recommended for any curved profile cutting. A cutter coolant system is recommended when processing.



Folding

To fold Atlas Steels AlFacade® once routed, the use of pan break or a break press machine is recommended, especially for large format panels.



Shearing

Atlas Steels AlFacade® panels can be guillotined face up for quick size processing of panels. Ensure the panel is protected from any potential damage during this process.



Perforating

Atlas Steels AlFacade® can be punched/perforated by turret punch machines, always punch the panels face up to the tooling, as a general rule 3.0mm minimum spacing between punched holes is required.



Roll forming

Mandrill roller systems can be used to produce curved/radius in Atlas Steels AlFacade® panels. Ensure roller sets are cleaned thoroughly before processing so not to damage the painted surface.



Screwing

When screw fixing Atlas Steels AlFacade® the use of stainless, class 3 or 4 SDS steel screws are recommended. A facade washer can also be implemented to protect painted surface, thermal expansion/contraction also needs to be allowed for.

Key Installation Details:

Positioning: Fasteners must be positioned at least 10mm from the edge of the panel to prevent damage.

Spacing: Maximum distance between fixings should not exceed 500mm to ensure stability.



Riveting

When rivet fixing Atlas Steels AlFacade® the use of stainless, or aluminium blind or solid rivets can be used. Protect painted surface from any possible damage, thermal expansion/contraction also needs to be allowed for.

Key Installation Details:

Positioning: Fasteners must be positioned at least 10mm from the edge of the panel to prevent damage.

Spacing: Maximum distance between fixings should not exceed 500mm to ensure stability.



Drilling

The use of high-speed steel (HSS) drills are recommended for any drilling required on Atlas Steels AlFacade®, always drill from the panel face so not to burr the painted surface.



Bending

Atlas Steels AlFacade® 3.0mm and 4.0mm panels can be folded by break press machines without having to be V routed, minor fracturing of the paint may occur which is acceptable under the Atlas Steels AlFacade® warranty.

07

Atlas Steels AlFacade® Warranty

This Warranty must be read and understood with the following product documents:

- Atlas Steels AlFacade® Installation and Technical Manual
- Atlas Steels AlFacade® Cleaning and Maintenance Schedule
- American Architectural Manufacturers Association voluntary standard AAMA2605.A

Atlas Steels warrants the AlFacade® panels coating:

- Will maintain its integrity as a facade panel for 20 years from the date of installation ("Warranty Period").
- Complies with AAMA2605.A
- Will not flake, blister, crack or peel when exposed to weather, except for minute fracturing on folds etc, that may occur during the fabrication process of the panels.
- Is applied to aluminium compliant to ASTM B209M.
- Any colour change or reduction of gloss of the surface coating will be in a uniform manner when surfaces are equally exposed to the sun & elements. The determination of colour differences & gloss reduction is to be done on clean panels from which deposits of foreign matter & chalk have been removed.

08

Atlas Steels AlFacade® Storage and Handling

Handling

Atlas Steels AlFacade® is a solid aluminum panel. Impact to the edge of the panel may cause deformation. Hard particles such as grains of dirt/sand, and cutting swarf can be caught between panels and may cause dents/scratches and possible damage to the adjacent panels when stacked together. Precautions need to be taken to ensure the panels are clean and free of any debris when handling Atlas Steels AlFacade® during unpacking and repacking process.

Transport

During transportation of Atlas Steels AlFacade® the panels must be packed flat on a correct size pallet to support the whole panel and never place other heavy loads on top of the panels. Always mark the packed material "Handle With Care," "No Top Load," clearly on the packaging.

Storage

Atlas Steels AlFacade® should always be stored indoors out of direct sunlight and rain, panels should be stored on a flat surface on pallets or a flat rack system. In a flat rack system, panels should also be stored on a rigid pallet, do not stack up varying sizes of panels together.

09

Atlas Steels Service Centre Locations

Victoria

Melbourne

2 /131 Calarco Drive
Derrimut VIC 3030

☎ (03) 9272 9999

✉ melbourne@atlassteels.com.au

Shepparton

14 McHarry Place
Shepparton VIC 3630

☎ (03) 5831 7955

✉ shepparton@atlassteels.com.au

South Australia

Adelaide

425-431 Grand Junction Road
Wingfield SA 5013

☎ (08) 8359 1100

✉ adelaide@atlassteels.com.au

Tasmania

Launceston

2-4 Derby Street
Mowbray TAS 7248

☎ (03) 6335 2700

✉ tas@atlassteels.com.au

New South Wales

Sydney

Unit 2, 1-5 Broadhurst Rd,
Ingleburn NSW 2565

☎ (02) 9825 7500

✉ nswsales@atlassteels.com.au

Newcastle

Unit1/13 Nelson Road
Cardiff NSW 2285

☎ (02) 4922 5566

✉ newcastlesales@atlassteels.com.au

Queensland

Brisbane

1302 Boundary Road
Wacol QLD 4076

☎ (07) 3246 9999

✉ qldsales@atlassteels.com.au

Mackay

42A Commercial Avenue
Paget QLD 4740

☎ (07) 4842 8000

✉ mackay@atlassteels.com.au